



Transport
for London

SME supplier of the year 2019



WILLIAM COOK RAIL

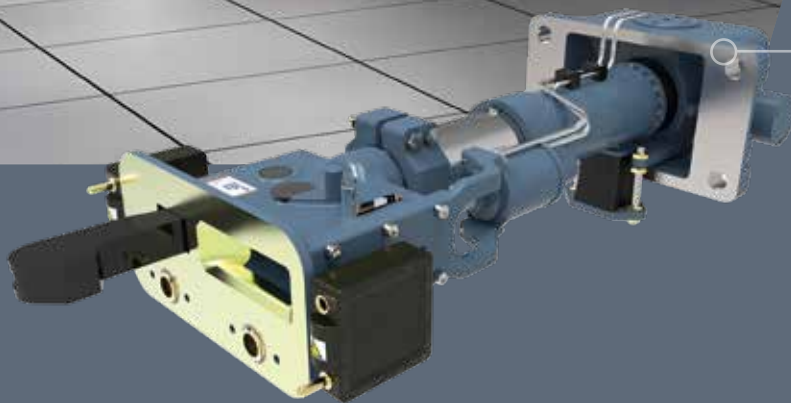

COMPACT WEDGELOCK COUPLER FOR LONDON UNDERGROUND

William Cook Rail is an Original Equipment Manufacturer of the wedgelock coupler, in service on all London Underground trains.

The new compact wedgelock coupler for the Deep Tube Upgrade Programme is designed to permit complete compatibility between new Siemens tube trains and existing London Underground rolling stock.

In 2019, Transport for London selected William Cook Rail as its SME Supplier of the Year for its continued support of London Underground and Tubelines.

Coupler systems

for trains and metros

William Cook Rail designs, manufactures and overhauls a wide range of couplers and drawgear for passenger and freight trains.

New couplers are manufactured from scratch using William Cook Rail's in-house foundry, machining, assembly and testing facilities.

Meanwhile, William Cook Rail's coupler overhaul workshop provides short turnaround services to rolling stock owners and operators.

ACCREDITATIONS AND APPROVALS

- ✓ IRIS
- ✓ RISAS
- ✓ RISQS
- ✓ Deutsche Bahn
- ✓ EN15085
- ✓ ISO 9001
- ✓ ISO 14001
- ✓ OHSAS 18001



Tube Lines

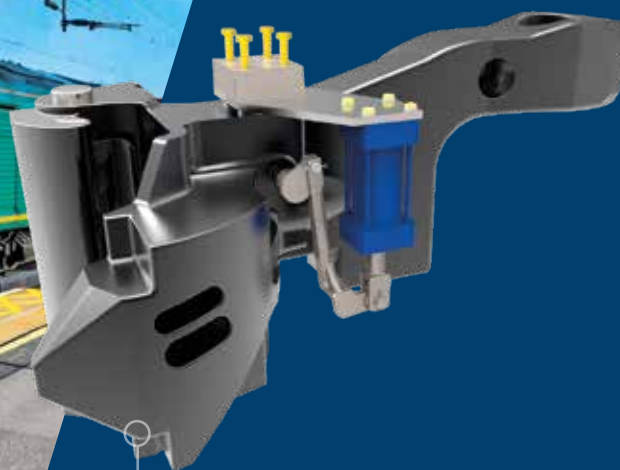

TIGHTLOCK AND COMBINATION COUPLERS

William Cook Rail designs, manufactures and overhauls tightlock couplers for passenger and freight trains. This proven and robust design can be adapted to different types of rolling stock, and supplied with a pneumatic coupling and uncoupling system.

William Cook Rail's innovative combination coupler is compatible with both screw and buckeye couplers, permitting compatibility between different types of rolling stock. William Cook Rail has supplied over 1,000 combination couplers to date.

Coupler maintenance, repair and overhaul

William Cook Rail's brand new coupler and bogie overhaul workshops provide maintenance, repair and overhaul services to support train operators.

Services offered include cleaning, shotblasting, non-destructive testing, welding in accordance with EN15085, re-machining, component replacement, painting and rebuild.

William Cook Rail also offers electrical and pneumatic maintenance and repair services for ancillary equipment.

AFTER REFURBISHMENT

BEFORE REFURBISHMENT



william-cook.co.uk
rail@cook-rail.co.uk
 +44 (0)113 249 6363
 Cross Green, Leeds, LS9 0DX, England